

# 2024 DIAMOND 4

**UNMATCHED 3-YEAR WARRANTY!**

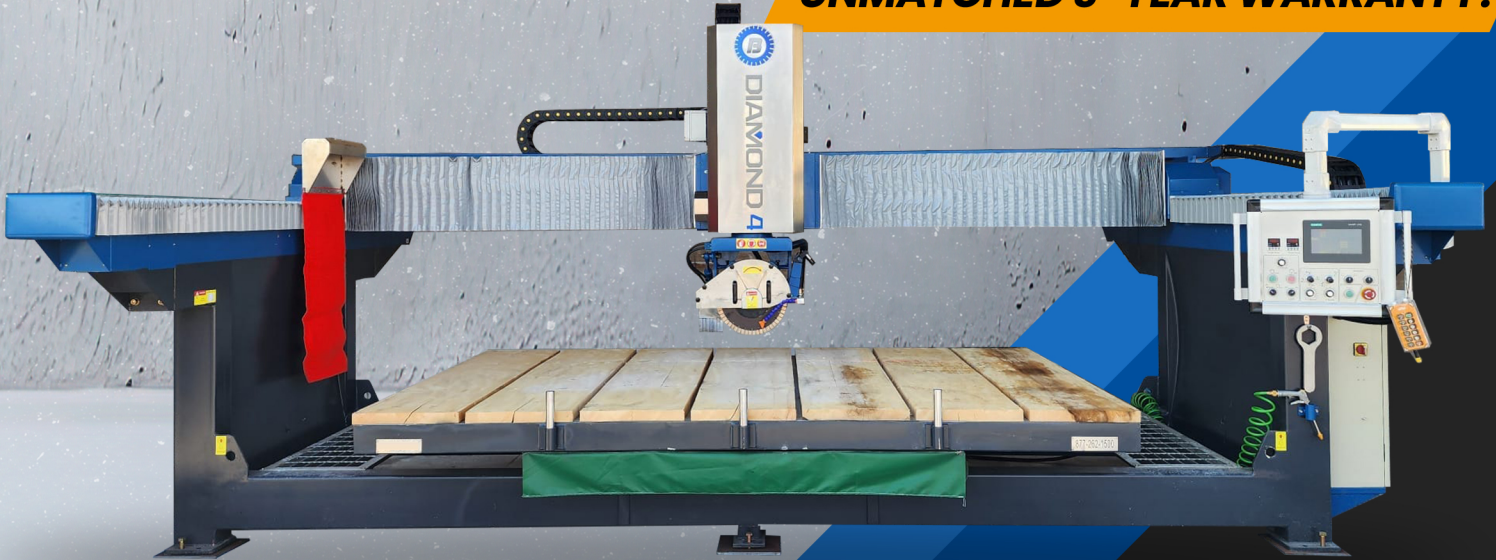

**INCLUDING DELIVERY, TRAINING,  
AND INSTALLATION\***

100% payment prior to shipment by  
Machine Tech Enterprises, LLC

- ☑ **Installation & Training: Included.**  
MTE will cover technician travel  
charges up to \$1400  
*(flight, hotel, car, etc. \*Outside of the 48  
US additional charges may apply)*
- ☑ **Shipping: Included** (\*Outside of 48  
US additional charges apply)
- ☑ **Tax: Additional dependent on  
location**
- ☑ **Warranty: 3 Year factory only  
Authorized Dealer**

 **MTE  
BRIDGE SAW**



**CALL TODAY! 877.262.1500**



**MTE**  
**BRIDGE SAW**

**DIAMOND 4**

*Relax, it's an MTE BridgeSaw.*

# CALL TODAY! 877.262.1500

## SPECIFICATIONS

- » Main Motor: 20hp, 67fla, 220v, 60hz, 3 phase
- » Cutting Engine Speed: 0 – 6000rpm
- » Production Rate: 78.75" – 98.5" per minute for 3cm quartz
- » Max Cutting Thickness: 2.95" using a 16"
- » Step Cutting: Two-way step cutting
- » Table Turn/Tilt Powered tilting 85° & Power rotating 0° – 360°
- » Head Tilt: 0°, 90°, 180°, & 270°
- » X axis plunge cutting
- » Head Rotation: 0° – 90°
- » Water Consumption: 8gpm
- Hydraulic Cut Length: Table size 137.8" x 82.68"  
» (Max cut 140"x140", Max miter cut 130" x 79")
- Dimensions (L x W x H): 231.81" x 150.79" x 96.34",  
» approx. 20' x 12.5' x 8'
- » Weight: 12500lbs
- » Saw blade diameter: 12" – 16"



## Features

- Main motor with inverter control for adjusting cutting speed and RPM's for different materials including, but not limited to marble, granite, quartz, etc.
- Monoblock steel structure
- Laser guided cutting
- Wireless remote control
- Siemens PLC control and Siemens touch screen, Siemens/Schneider contactor and breaker, Schneider intermediate relay
- 100 PC fully programmable cutting
- Operator panel in fixed location at the front of the machine – no need to move back and forth with the machine
- Fully powered miter cutting
- Plunge cutting miter
- Hydraulic powered rotating table
- Auto on/off water



[www.bridgesaw.com](http://www.bridgesaw.com)





MTE  
**BRIDGE SAW**

**DIAMOND 4**

*Relax, it's an MTE BridgeSaw.*

**CALL TODAY! 877.262.1500**

## Machine Measurements

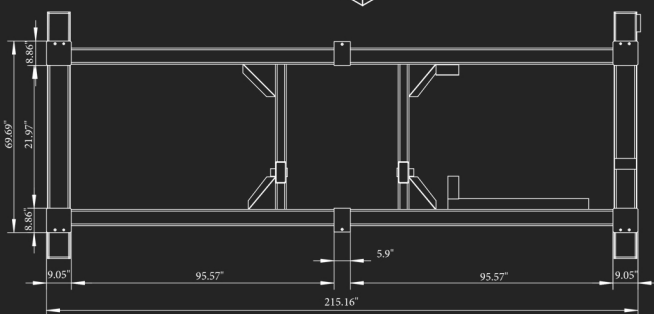
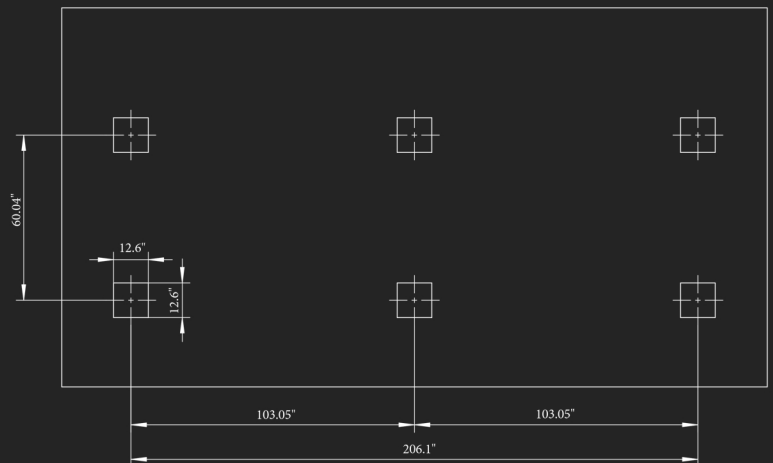
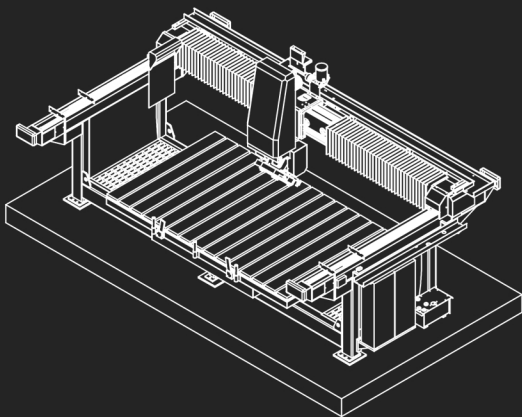
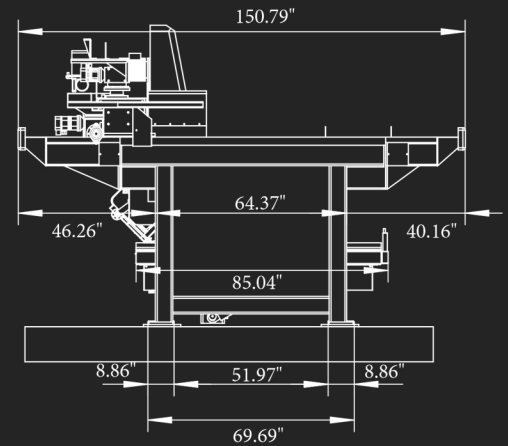
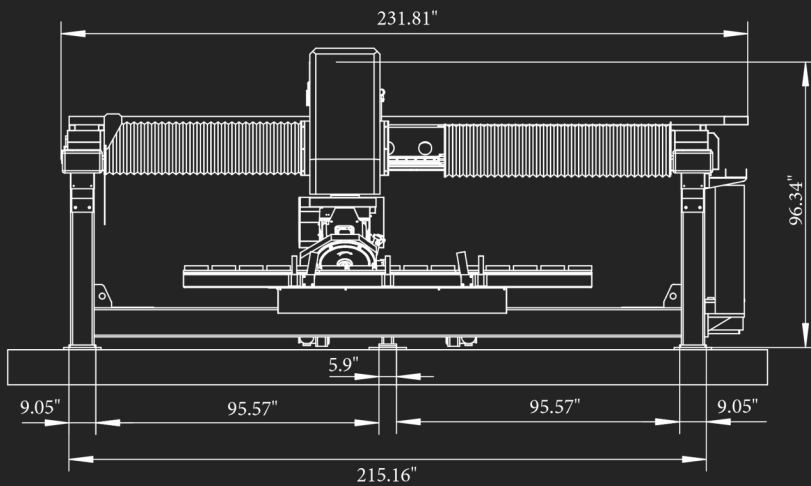

[www.bridgesaw.com](http://www.bridgesaw.com)