

2024  
**DIAMOND 5 CNC Saw**

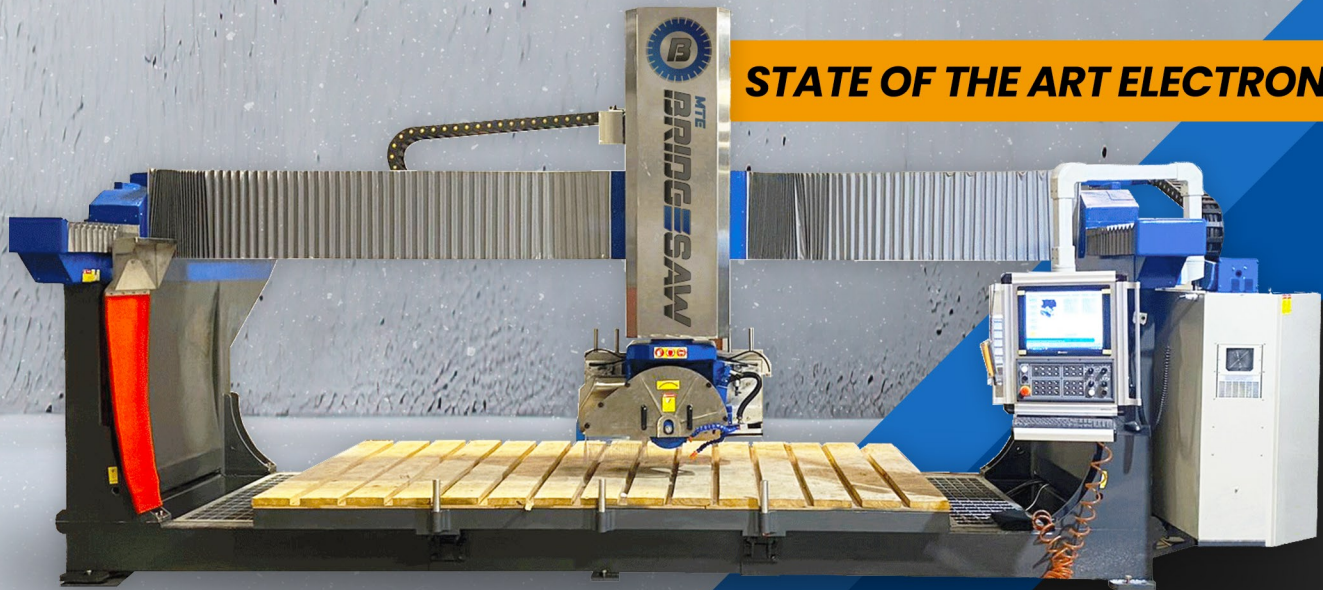

**STATE OF THE ART ELECTRONICS**

**INCLUDING DELIVERY, TRAINING,  
AND INSTALLATION\***

100% payment prior to shipment by  
Machine Tech Enterprises, LLC

- ✔ **Installation & Training: Included.**  
MTE will cover technician travel  
charges up to \$1400  
*(flight, hotel, car, etc. \*Outside of the 48  
US additional charges may apply)*
- ✔ **Shipping: Included**  
*(\*Outside of 48 US additional charges  
apply)*
- ✔ **Tax: Additional dependent on  
location**
- ✔ **Warranty: 3 Year factory only  
Authorized Dealer**

 **MTE  
BRIDGE SAW**

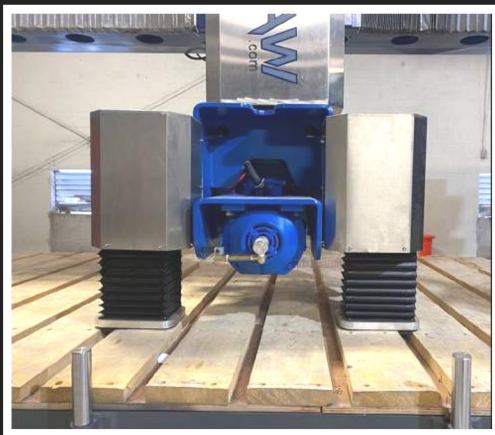

**CALL TODAY! 877.262.1500**



**DIAMOND 5 CNC Saw**

*Relax, it's an MTE BridgeSaw.*

# CALL TODAY! 877.262.1500

## FEATURES

- Automatic tool measurement
- Hydraulic tilting table
- Easy to use programming software
- 5 interpolated axis for complex cutting
- Router bit for sink cutouts & inside corners
- Vacuum system for material saving and nesting
- State of the art electronics
- Easy to use CAD/CAM software
- A camera is used for slab setup
- Integration with laser templating
- Slab thickness probe
- Additional 2400 rpm spindle allows for more efficiency and faster speed for milling corner

## SPECIFICATIONS

- » Minimum Disc Diameter: 13.7"
- » Maximum Disc Diameter: 18"
- » Work table dimensions: 138.8" x 82.6"
- » Carriage Stroke Axis X: 142"
- » Bridge Stroke Axis Y: 87"
- » Vertical stroke of head Axis Z: 12"
- » Disk head rotation (Axis C): 0°/365°
- » Disk head tilting movement (Axis A): 0°/90°
- » Max cutting depth: 7"
- » Spindle motor power: 18kw
- » Additional Spindle 5.5kw max, 2400 rpm
- » Standard voltage: 220v/50-60hz 3 phase V
- » CNC system: ESA
- » Cut Cam: Zeus+

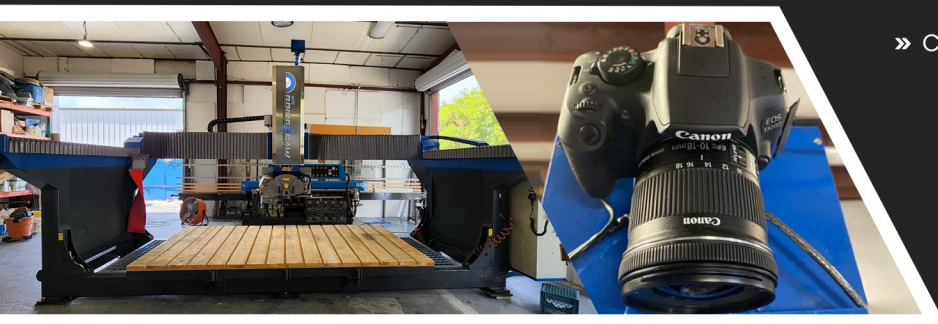

[www.bridgesaw.com](http://www.bridgesaw.com)

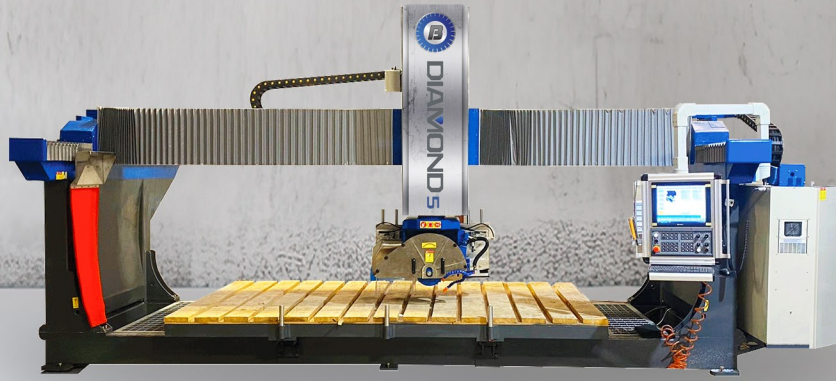

**MTE**  
**BRIDGE-SAW**

**DIAMOND 5 CNC Saw**

*Relax, it's an MTE BridgeSaw.*

**CALL TODAY! 877.262.1500**

## Machine Measurements

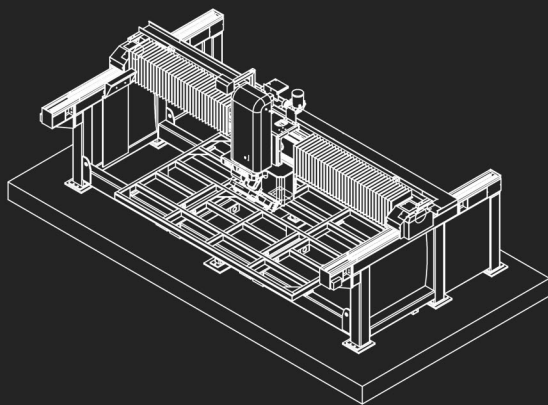
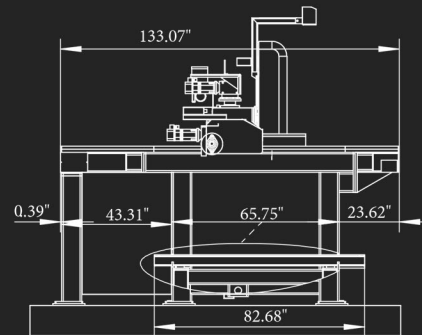
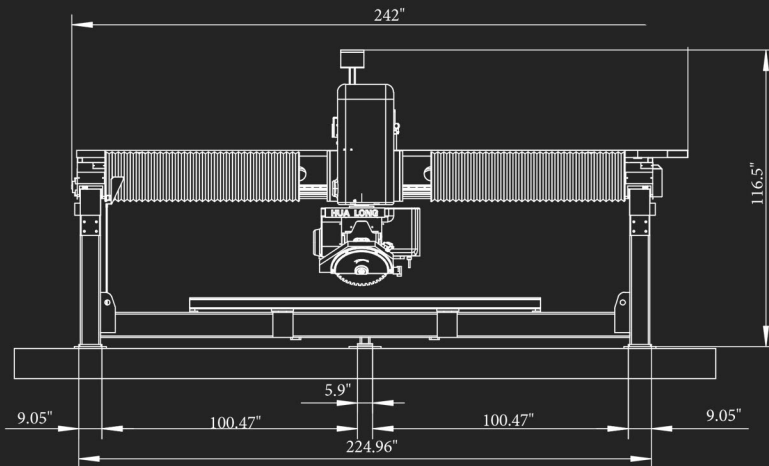



**MTE**  
**BRIDGE-SAW**

**DIAMOND 5 CNC Saw**

*Relax, it's an MTE BridgeSaw.*

**CALL TODAY! 877.262.1500**

## Machine Measurements

